

Fevik 1000/2000 Twilight

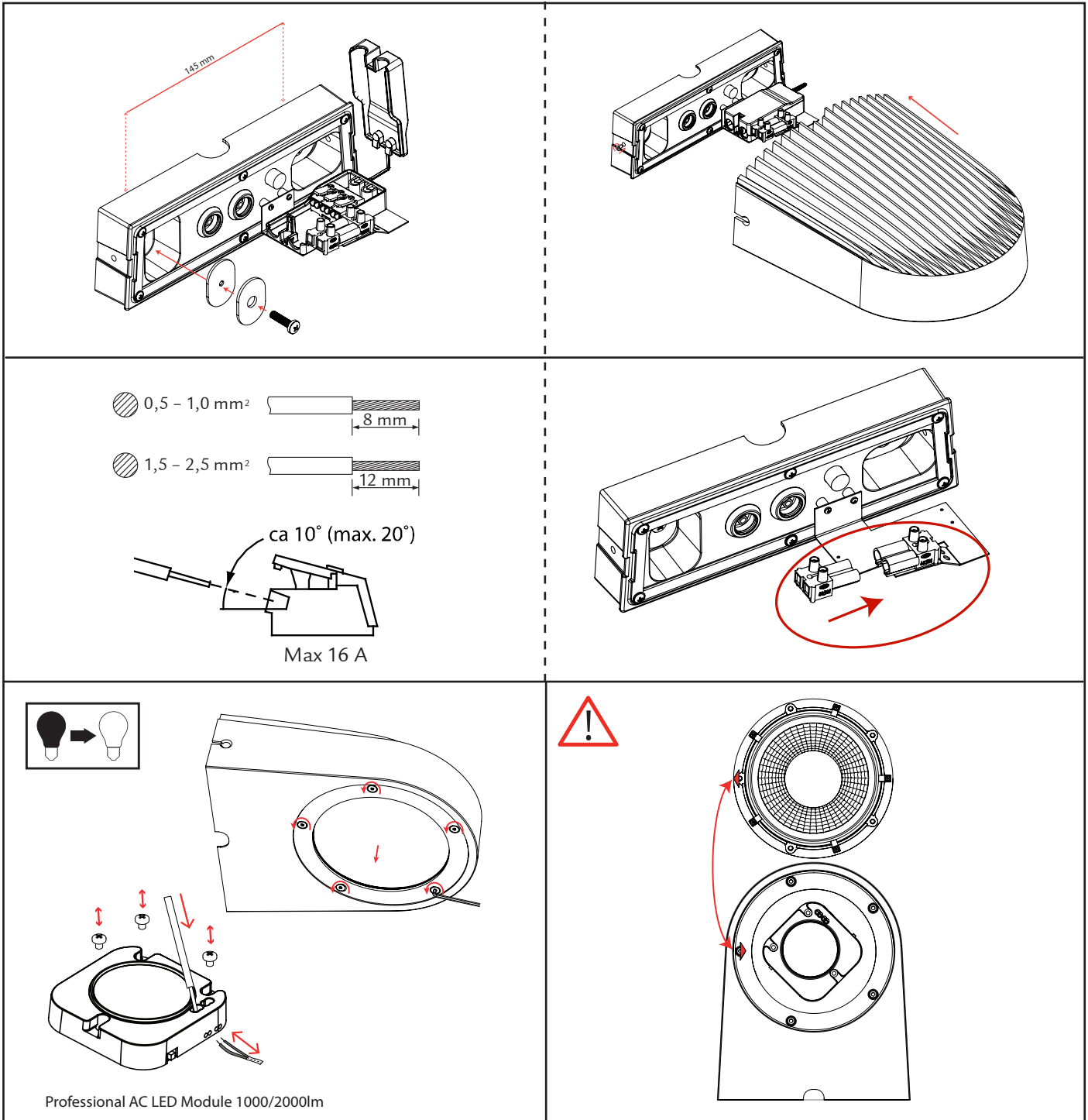

220-240V, 50/60Hz



Rev: 28.01.2022

NORWAY
SG Armaturen AS

Skytterheia 25
N-4790 Lillesand

Tel: +47 37 50 03 00
firmapost@sg-as.no
www.sg-as.no

SWEDEN
SG Armaturen AB
Tel: +46 31 81 71 10
info@sg-ab.se
www.sg-ab.se

FINLAND
SG Armaturen Oy
Tel: +358 02 07 30 39 60
info@sg-oy.fi
www.sg-oy.fi

DENMARK
SG Armaturen A/S
Tel: +45 70 70 72 13
info@sg-as.dk
www.sg-as.dk

UNITED KINGDOM
SG Lighting LTD
Tel: +47 37 50 03 00
info@sglighting.co.uk
www.sglighting.co.uk

FRANCE
SG Lighting SA/NV
Tel: +33(0) 4 94 93 00 00
info.france@sglighting.fr
www.sglighting.net

BENELUX
SG Lighting SA/NV
Tel: +32(0) 15 20 72 71
info.benelux@sglighting.net
www.sglighting.net

GERMANY
SG Leuchten GmbH
Tel: +49 40 23 99 44 59
info@sg-leuchten.de
www.sg-leuchten.de

INTERNATIONAL
SG Lighting Co Ltd.
Tel: +86 769 88 49 20 88
cindy@sgdgc.com
www.sg-as.com

Dipswitch

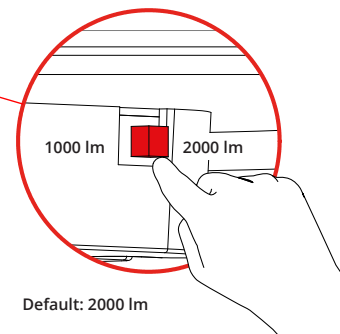
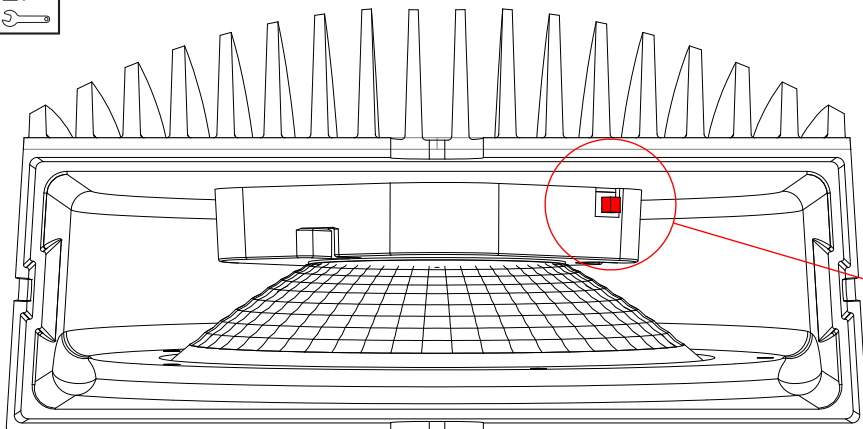
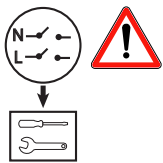

Default: 2000 lm

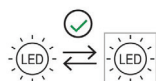

NO: Kan kun installeres og vedlikeholdes av en registrert installasjonsvirksomhet.

EN: Only to be installed and maintained by an authorized electrician.

FR: Doit être installé et maintenu par un électricien qualifié.

DK: Må kun installeres og vedligeholdes af uddannet elektriker.

SE: Skall installeras och underhållas av behörig elektriker.

NL: Mag alleen geïnstalleerd en onderhouden worden door een bevoegde elektricien..

DE: Dieses Produkt darf nur durch autorisiertes Personal angeschlossen, in Betrieb genommen und gewartet werden.

FI: Asentaa ja huoltaa saa vain valtuutettu sähköasentaja

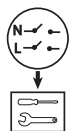

NO: Skru av strømmen før montering.

EN: Turn off power before installing.

DK: Sluk for strømmen inden montering.

SE: Stäng av strømmen innan montering.

FR: Couper le courant avant l'installation.

NL: Stroom uitschakelen voor u het toestel installeert.

DE: Vor Installationsarbeiten den Strom abschalten.

FI: Sammuta virta ennen kytkemistä



NO: Skru av strømmen før skifte av lyskilde

EN: Turn off power before relamping

DK: Sluk strømmen inden lyskildeskift

SE: Bryt spänningen innan du byter ljuskälla

FR: Couper le courant avant de changer la lampe

NL: Stroom uitschakelen voor u de lamp vervangt

DE: Vor dem Entfernen des Leuchtmittels den Strom abschalten.

FI: Katkaise virta ennen lampun vaihtamista

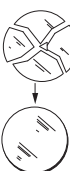

NO: Skadet glass må erstattes med nytt.

EN: Damaged glass must be replaced.

DK: Beskadiget glas skal udskiftes

SE: Skadat glas måste ersättas med nytt.

FR: Tout verre endommagé doit être remplacé.

NL: Gebroken glas moet vervangen worden.

DE: Glasscherben müssen ausgetauscht werden.



FI: Vaurioitunut lasi on vaihdettava

Twilight sensor

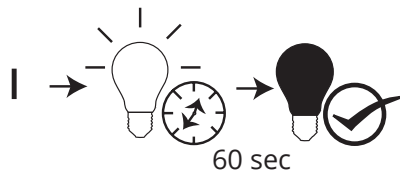

220-240V, 50/60Hz



	< 0,5 W
Max.	200 W
IR	
IR	LED



Alt A

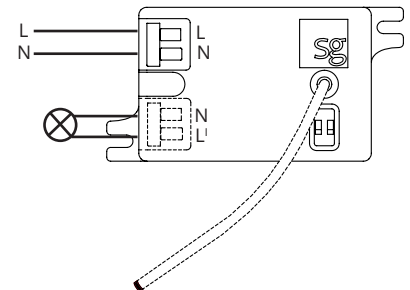

Alt B

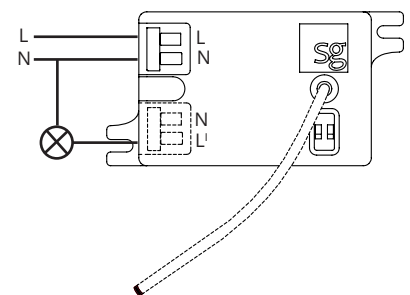

Sensor LUX Level

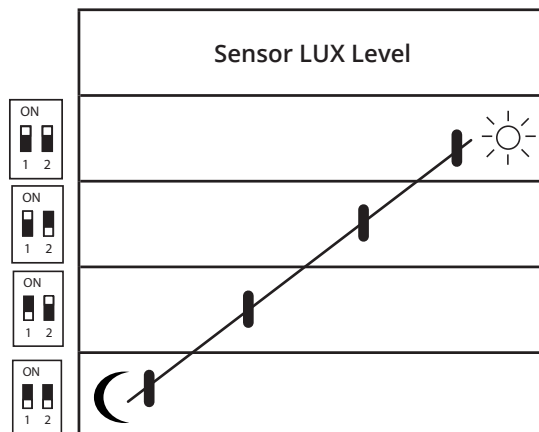

NORWAY

SG Armaturen AS

Skytterheia 25
N-4790 Lillesand

Tel: +47 37 50 03 00
firmapost@sg-as.no
www.sg-as.no

SWEDEN

SG Armaturen AB
Tel: +46 31 81 71 10
info@sg-ab.se
www.sg-ab.se

FINLAND

SG Armaturen Oy
Tel: +358 02 07 30 39 60
info@sg-oy.fi
www.sg-oy.fi

DENMARK

SG Armaturen A/S
Tel: +45 70 70 72 13
info@sg-as.dk
www.sg-as.dk

UNITED KINGDOM

SG Lighting LTD
Tel: +47 37 50 03 00
info@sglighting.co.uk
www.sglighting.co.uk

FRANCE

SG Lighting SA/NV
Tel: +33(0) 4 94 93 00 00
info.france@sglighting.fr
www.sglighting.net

BENELUX

SG Lighting SA/NV
Tel: +32(0) 15 20 72 71
info.benelux@sglighting.net
www.sglighting.net

GERMANY

SG Leuchten GmbH
Tel: +49 40 23 99 44 59
info@sg-leuchten.de
www.sg-leuchten.de

INTERNATIONAL

SG Lighting Co Ltd.
Tel: +86 769 88 49 20 88
cindy@sgdgc.com
www.sg-as.com